

QUEENSLAND.

Bureau of Sugar Experiment Stations

Division of Entomology.

---

FARM BULLETIN No. 9.

---

Monthly Notes on  
The Greyback Cane Beetle and  
Its Control

by

EDMUND JARVIS, Entomologist.

---

Issued by direction of the Hon. F. W. BULCOCK,  
Minister for Agriculture and Stock.

---



BRISBANE:

By Authority: Frederick Phillips, Government Printer.

# INDEX



	PAGE.
<b>JANUARY</b>	
Completion of fighting and egg-laying of Greyback. Grubs of first stage attain maximum development .. .. .	5
<b>FEBRUARY</b>	
End of egg and beetle seasons. Commencement of fumigation. Grubs of first and second stages found in canefields. Table showing when to fumigate grub-infested cane land .. .. .	7
<b>MARCH</b>	
External indications of damage to roots of sugar-cane. Occurrence of grubs of second and third stages. Use of hand injector for fumigating cane grubs .. .. .	11
<b>APRIL</b>	
Great destruction of cane by grubs of Greyback beetle. Predominance and maximum activity of third-stage grubs ..	15
<b>MAY</b>	
Complete destruction of cane stools by mature grubs. Grubs commence tunnelling down to construct pupal cells .. ..	17
<b>JUNE</b>	
Most of the grubs preparing to transform into pupæ. Influence of moisture on final position of the pupa .. .. .	21
<b>JULY</b>	
Commencement of the pupal life-cycle stage of Greyback. End of period of activity of grubs of the Greyback. Month for ordering supplies of fumigants from the mill .. .. .	25
<b>AUGUST</b>	
Economic significance of the pupal stage of development. Occurrence of both grubs and pupæ in subterranean cells. Transformation of pupæ to the winged beetle condition .. .. .	27
<b>SEPTEMBER</b>	
Overhauling and repairing hand injector: how to use same. Predominance of the pupa stage of Greyback cockchafer ..	29
<b>OCTOBER</b>	
Beetles lying in pupal cells attaining strength for flight. Pupæ derived from late broods of grubs still occur in cells ..	33
<b>NOVEMBER</b>	
First appearance of eggs and young grubs in canefields. Greyback cockchafers emerge from the ground this month .. .. .	35
<b>DECEMBER</b>	
First-stage grubs of Greyback are usually in evidence. Flighting and egg-laying period of Greyback cane beetle .. .. .	39

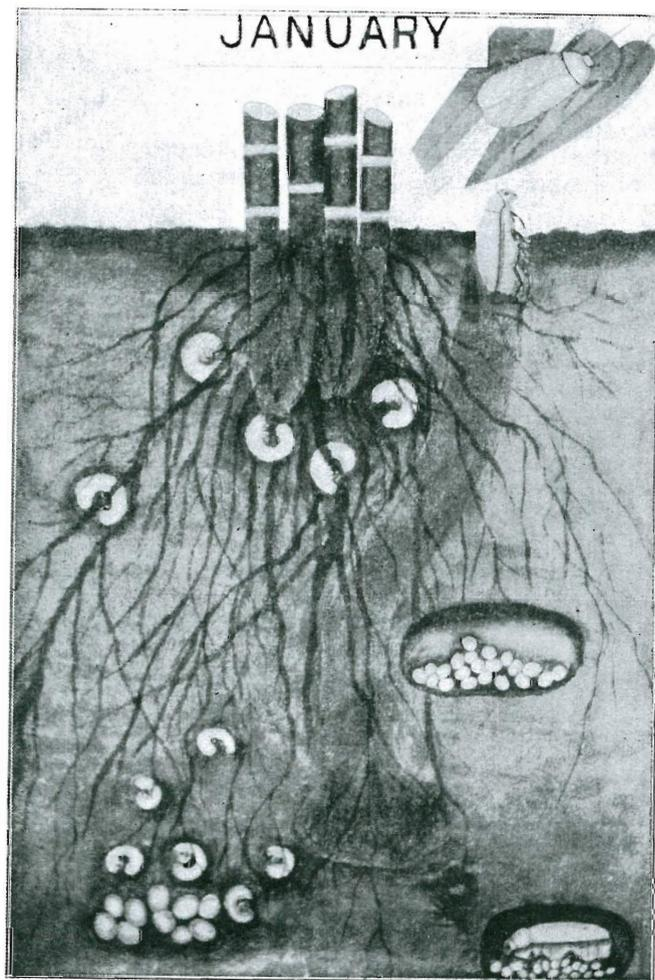

PLATE I.

Habits of the Greyback Cockchafer Beetle and its young Grubs during the month of January.

## JANUARY.

### COMPLETION OF FLIGHTING AND EGG-LAYING OF GREYBACK. GRUBS OF FIRST STAGE ATTAIN MAXIMUM DEVELOPMENT.

THE first two or three weeks in January offer special interest and attractions to lovers of Nature Study; the winged or aerial existence of our cane beetle being now everywhere in evidence. In the day time these large grey cockchafers can often be seen clustering thickly on bushes by the roadside; while the branches of many big feeding-trees around the paddock or homestead are literally bending beneath the accumulated weight of tens of thousands of beetles clinging to twigs and leaves. Such abundant evidence of insect life, although admittedly more or less spectacular, too often foreshadows injury to cane crops in the near future.

#### Description of the Greyback Cockchafer (*Lepidoderma albohirtum* Waterh.).

The average size and shape of this beetle is shown in Fig. 1, page 5. Although in reality of a deep brown colour, it has earned the popular name of grey or mealy-back on account of its body being thickly covered on the upper surface and sides of abdomen with minute whitish pear-shaped scales which are readily detachable.

Freshly emerged specimens appear uniformly grey, but after a few days on the wing become more or less rubbed, such denuded portions of wing-cases showing amongst the layer of scales as irregular dark blotches.

The antennæ or so-called "feelers" end in a large club, composed of five plates in the male and four in the female beetle. Long bristly red hairs occur on hind margin of head, frontal portion of eyes, various parts of the mouth, front edge of thorax, and other places. The outer portion of front leg possesses two large, bluntly-pointed teeth, and a smaller almost central rather sharp tooth.

#### Predominance of the Egg-laying Period.

The commencement and mode of oviposition of the Greyback is described on page 39, and would naturally apply also to beetles chancing to emerge from the ground at the end of December, which would oviposit about the middle of January. During the present month, however, eggs of this pest are generally more plentiful than at any other time of year, and may now be found in the soil at depths of 12 to 15 in. or more in all stages of development, from  $\frac{1}{8}$  to nearly  $\frac{1}{4}$  in. in diameter.

#### Greyback Cane Grubs Found During this Month.

In years when these cockchafers chance to appear on the wing in November, one can find larvæ in both first and second stages of growth during the month of January. In such seasons those of the first stage may occur in various sizes from  $\frac{1}{8}$  to  $\frac{1}{4}$  in. long; the head, however, invariably being  $\frac{1}{8}$  in. wide, and remaining so during the whole time occupied in development of the first instar.

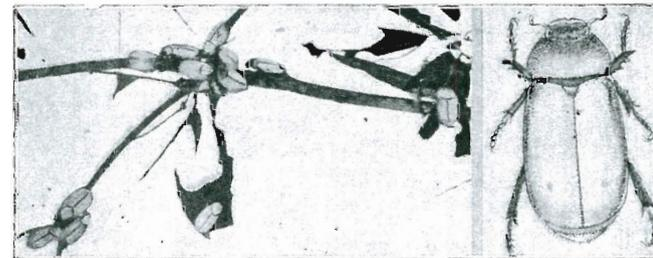

Fig. 1.

Fig leaves (*Ficus pilosa*) being eaten by the Greybacks, together with a picture of the beetle slightly reduced.

Should the head be found to measure exactly a  $\frac{1}{4}$  in. in width, one can be certain that such grubs have moulted (changed their skin) and commenced the second stage of growth, during which period of about thirty-eight days the body attains a length of  $1\frac{1}{4}$  in., although the head (let it be remembered) does not increase in size.

#### How to Destroy the Greyback Beetle, Its Eggs, and First Stage Grubs.

In seasons when Greybacks fail to appear until late December, the recommendations offered with regard to means of destroying them would apply also to January. Long continued dry weather will sometimes cause very heavy mortality among these beetles, and when operating over immense areas of forest land exercises an ideal natural remedy. Collecting the beetles is perhaps the best-known commonsense control method, having yielded beneficial results both in Australia and other countries. This is usually practised during seasons when the pest chances to be very plentiful, although it seems reasonable to assume that remedies of this kind might give us best results during years when such natural checks happen to have thinned the enemy's ranks, since any additional destruction of the survivors should tend to act as a kind of knockout blow, by prolonging the period which must necessarily elapse before the succeeding broods of this cockchafer could once more finally regain normal numerical force.

#### Destroying Eggs of the Greyback.

Experiments conducted by the present writer in November of 1921 provided conclusive proof that these eggs could be killed in a few hours by fumigating the soil above them with carbon bisulphide. Commonsense control measures against the eggs and newly-hatched grubs may also, to some extent, be effected by certain cultural operations. For instance, by keeping a strip of ground about 15 in. wide on each side of a cane row loosened up and free from weeds at commencement of the fighting season, and maintaining such state of friability about four to five weeks, one can take advantage of a habit common to many scarabæid beetles of ovipositing by preference in unbroken ground; the firm condition of which, by affording a suitable fulcrum, enables these insects to easily retain the correct position assumed when excavating their subterranean tunnels.

Such movement of the upper soil during a period of five to six weeks (commencing about a month after the first emergence of beetles) will often destroy a certain percentage of grubs of the first stage, which occur at times comparatively near the surface, by breaking up their feeding-tunnels, thus exposing them to attacks from various foraging ants.

Endeavour, if possible, to have the soil between cane rows well worked and free from weeds before greybacks appear on the wing, and throughout the fighting and egg-laying periods. A luxuriant growth of weeds, &c., amongst the stools is strongly attractive to egg-laden females of the Greyback cane beetle.

At this time of the year when eggs and small grubs of the pest are much in evidence, it is advisable to keep the surface soil in good "heart," as near to the stools as can be conveniently effected without risking material injury to the cane plants.

The plate for January resembles somewhat that for December. Greyback beetles are still in the feeding-trees, or ovipositing in the ground. Eggs are hatching, and grubs of the first-stage feeding on cane roots near the surface are preparing to moult into the second stage of development.

## FEBRUARY.

### END OF EGG AND BEETLE SEASONS. COMMENCEMENT OF FUMIGATION.

#### GRUBS OF FIRST AND SECOND STAGES FOUND IN CANE FIELDS. TABLE SHOWING WHEN TO FUMIGATE GRUB-INFESTED CANE LAND.

THE beetle and egg phases in the life cycle of our Greyback cockchafer have now been completed, and during the present month its destructive grubs will dominate the field of activity. Although a few first-stage larvæ can still be found, the majority of grubs will either enter upon or complete the course of their second instar of growth; while about the end of February a small percentage of these may be expected to moult into the third stage, thereby assuming the voracious well-known form in which, during the next three months (March to May), they are known to cause wilting of the leaves or death of infested cane stools.

The grub and its varied subterranean movements may lay claim, therefore, to our chief consideration during the month of February; its habits, structure, control, mode of injury to cane, and inter-relationships with both parasitic and predaceous insect enemies, presenting a wide and most interesting field for scientific research.

The silent, though sinister, underground activities of this pest, although hidden from observation, should not be deemed less menacing on that account. Coming events have already cast their shadows before, but it is feared that many growers who, during the fighting season of the beetles, were unpleasantly reminded of what might befall their crops later on, are, nevertheless, too apt—while surveying their apparently flourishing cane during February—to ignore such warnings, and continue unduly optimistic as to future harvesting results.

It should be borne in mind that even Greyback grubs of the second instar of development when little more than an inch long are able at times to seriously injure young plant cane. On blocks, for instance, where early infestation chances to average twelve to fifteen such grubs per stool, the crop is sometimes fairly eaten out of the ground and totally ruined.

#### The Second Stage Grub.

External evidence of root damage caused by these grubs in February is not as a rule very noticeable during seasons of ordinary beetle infestation. Although acting the part of a good second, the most aggressive capabilities of second-stage grubs, however, attain maximum force when united with those commencing the third instar of growth, which generally happens about the middle of March.

#### Habits and Movements of the Grubs.

The nature of damage to cane from larvæ of this cockchafer is too well known to need more than brief comment. After wet weather, small first-stage grubs will often move upwards to within about 4 in. from the surface to feed upon succulent young upper roots; and during the following fortnight or three weeks, while increasing slowly in size, will sometimes penetrate to a depth of 6 or 7 in., and after moulting into the second instar start to feed more voraciously upon larger roots.

Ultimately, when entering upon their third stage of development (which often occurs about the end of February), they are usually found feeding in company with grubs of the second stage; turning their attention, however, to the large cord-like cane roots, the function of which is to furnish a constant supply of water to the sticks and leaves, while serving also to anchor and maintain the stools in rigid upright position.

During February Greyback grubs of the second stage may be said to predominate, and have now attained sufficient size to attract notice from cane farmers and cause more or less anxiety.

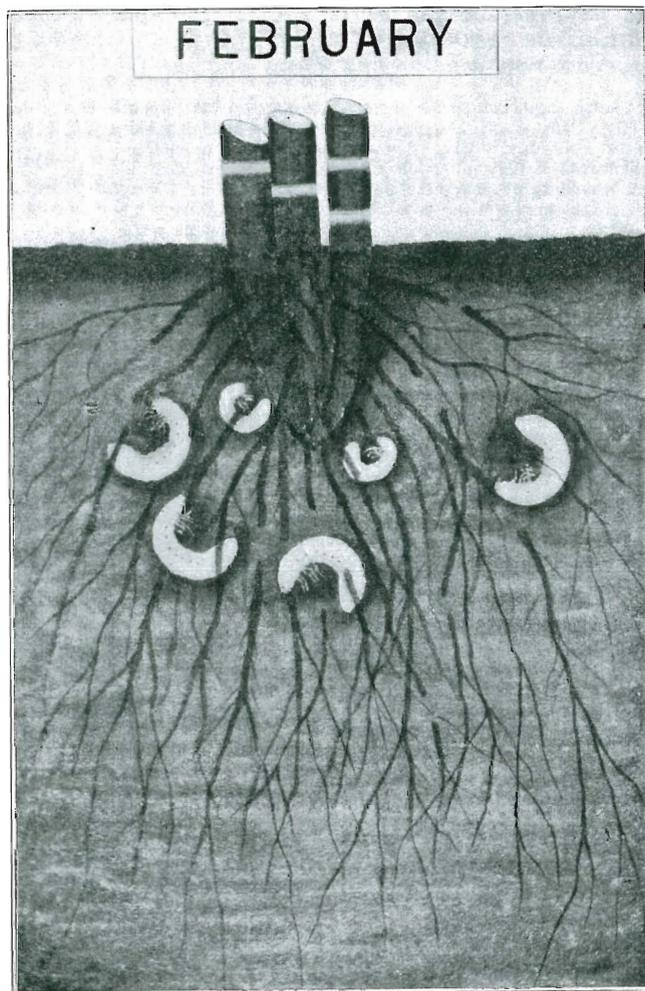

PLATE II.  
Activities of the Second-stage Grubs of our Greyback Cockchafer Beetle during February.

#### Shape and Colour of Grub.

The familiar doubled up appearance of grubs of the greyback (a form common to that of most scarabæid beetles) remains practically the same throughout the long period passed in its larval condition. During the course of the second instar of growth, the head, as pointed out earlier, is always a quarter of an inch wide, the general colour of the body being creamy white, but somewhat bluish and translucent just after moulting. The large anal or last body segment is plainly suffused with dark grey, blue, or brown, due to the internal presence and varying colour of the kind of soil being ingested by the grub showing through its thin semi-transparent skin. On the lower surface of this terminal segment are two parallel rows of short, reddish spine-like hairs, about twenty-four in each row, surrounded on either side by numerous longer scattered bristles (see illustration).

#### How to Destroy Cane Grubs.

Combating the cane beetle during its larval condition has been found to yield best results, since this life cycle stage occupies a period of about five months of the year. Recent successes achieved against its grubs by the practice of soil fumigation have definitely established this control measure on a firm basis; the practical value of both carbon bisulphide and paradichlorobenzene having been demonstrated by field experiments carried out at the Greenhills Estate and by many of our growers in the Northern districts.

In view of the fact that secondary emergences are liable to occur in certain localities about the middle of December, and fumigation work commences in such areas about the end of February, it becomes advisable to describe briefly the method usually adopted when injecting soil fumigants. Before doing so, however, the table below giving correct dates on which to start such work should be consulted, bearing in mind that the periods shown thereon (from date of commencement of flighting season to that of injection of the cane) apply to the last emergence of cane beetles noticed by the farmer concerned. In those districts receiving sufficient rain to bring about a primary emergence of beetles during November, followed by a secondary brood a few weeks later, the period given in the table—from emergence of beetles to time to fumigate—should be extended in such cases to about 100 days, in order to make sure of killing the grubs from both emergences.

WHEN TO FUMIGATE GRUB-INFESTED CANE LAND.

Beetles Emerge.	Time to Fumigate.	Beetles Emerge.	Time to Fumigate.	Beetles Emerge.	Time to Fumigate.
Nov. 18	Jan. 27	Dec. 7	Feb. 15	Dec. 26	Mar. 6
Nov. 19	Jan. 28	Dec. 8	Feb. 16	Dec. 27	Mar. 7
Nov. 20	Jan. 29	Dec. 9	Feb. 17	Dec. 28	Mar. 8
Nov. 21	Jan. 30	Dec. 10	Feb. 18	Dec. 29	Mar. 9
Nov. 22	Jan. 31	Dec. 11	Feb. 19	Dec. 30	Mar. 10
Nov. 23	Feb. 1	Dec. 12	Feb. 20	Dec. 31	Mar. 11
Nov. 24	Feb. 2	Dec. 13	Feb. 21	Jan. 1	Mar. 12
Nov. 25	Feb. 3	Dec. 14	Feb. 22	Jan. 2	Mar. 13
Nov. 26	Feb. 4	Dec. 15	Feb. 23	Jan. 3	Mar. 14
Nov. 27	Feb. 5	Dec. 16	Feb. 24	Jan. 4	Mar. 15
Nov. 28	Feb. 6	Dec. 17	Feb. 25	Jan. 5	Mar. 16
Nov. 29	Feb. 7	Dec. 18	Feb. 26	Jan. 6	Mar. 17
Nov. 30	Feb. 8	Dec. 19	Feb. 27	Jan. 7	Mar. 18
Dec. 1	Feb. 9	Dec. 20	Feb. 28	Jan. 8	Mar. 19
Dec. 2	Feb. 10	Dec. 21	Mar. 1	Jan. 9	Mar. 20
Dec. 3	Feb. 11	Dec. 22	Mar. 2	Jan. 10	Mar. 21
Dec. 4	Feb. 12	Dec. 23	Mar. 3	Jan. 11	Mar. 22
Dec. 5	Feb. 13	Dec. 24	Mar. 4	Jan. 12	Mar. 23
Dec. 6	Feb. 14	Dec. 25	Mar. 5	Jan. 13	Mar. 24

#### Determining Degree of Grub Infestation.

Commence your examination in the middle of any block of cane thought likely to be grub infested by removing the soil from around the base of a stool. Should grubs occur amongst the side roots in numbers of four to eight or more, such stools need not be dug out. After recording the results obtained, a second stool, about

a chain further on in the same row, should be treated in similar manner, and followed up by successive examinations of others in the same row at intervals of a chain. Every fourteenth row in the block to right and left of the one examined should then receive similar inspection. If obtaining an average of three or more grubs per stool the area should be fumigated.

In years when the final emergence of beetles chances to take place about the middle of December, scouting is usually commenced a couple of months later.

#### How to Use the Hand-Injector.

Before fumigating, see that the soil is in a favourable state at the time of application, in order that the volatile fumes may be able to permeate freely between the tiny soil particles. In other words, it must on no account be water-logged or in a saturated condition, such as often prevails for a day or so following a heavy downpour. The land must not be too dry or too wet, but in a state in which it could, if desired, be cultivated with the best results. Naturally, well-drained lands of a light nature attain this desirable state of aeration in two or three days, while clay-loams might take four days, or even longer in the case of poorly drained low-lying areas.



Fig. 2.

Typical Shape of Grub of Greyback Cane-Beetle.

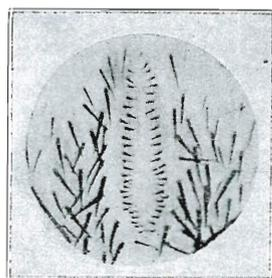

Fig. 3.

Arrangement of the Central Bristles on Anal Segment of Grub.

Familiarity with the construction of the hand-injector will be found helpful if something goes wrong with the mechanism; in such cases, however, advice can always be obtained from the Cane Inspector, or the Entomologist.

Before starting, see that the foot-rest on injector is in correct position for administration of the fumigant just above the level at which grubs chance to be feeding at the time. The usual dosage for carbon bisulphide is  $\frac{1}{4}$ th oz., equivalent to about  $4\frac{1}{2}$  cc.; a similar dosage being the 1 drachm 20 minims, which represents about 4 cc., and is the quantity discharged by Danks' injector when set at No. 5 (see September notes, page 29).

Injections are made about 1 ft. apart on both sides of a cane row, 3 in. from stools and 4 to 4 $\frac{1}{2}$  in. deep. The number of stabs given will depend to some extent on the age of the crop being treated, on the size of the stools, and existing soil porosity. In some instances, it has been found advisable to give five or even six injections to certain large stools in order to ensure best results.

If mixing paradichlorobenzene with carbon bisulphide 60 lb. of the former are generally dissolved in about 5 gallons of the liquid carrier. This should be stirred well, and when completely dissolved filtered through copper gauze before pouring into the injector. During the course of fumigation examine a few of the treated stools at intervals of a day or so to note nature of results. Test the pumps above ground occasionally to make sure the dose is being discharged in uniform and correct quantity, and at each stroke of the plunger.

The February plate shows the commencement of damage of a material nature to roots of sugar-cane by second-stage grubs of the Greyback cockchafer; external indications of which, however, are not usually apparent until next month.

## MARCH.

### EXTERNAL INDICATIONS OF DAMAGE TO ROOTS OF SUGAR-CANE. OCCURRENCE OF GRUBS OF SECOND AND THIRD STAGES. USE OF HAND INJECTOR FOR FUMIGATING CANE GRUBS.

Towards the end of this month the heart leaves of cane growing on badly grub-infested blocks begin to lose their normal bright green colour and assume a greyish somewhat wilted appearance. At midday, during dry weather, it will be noticed, too, that the blades of central leaves display a tendency to curl over from each side of the midrib, the entire leaf becoming of nearly tubular form. In the next stage of injury this curling of the leaves can often be seen on cloudy or wet days. The above symptoms indicate inability of such affected canes to obtain sufficient water, owing to grubs having severed most of the large main roots. A little later, these central heart leaves soon take on a yellowish colour, which gradually darkens to brown before final drying-up of the cane tops.

Widely spread destruction of stools is not generally witnessed, however, until later on, in April and May.

#### Description of the Third-stage Grub.

Although closely resembling grubs of the second stage in general appearance the fully grown or third-stage larva possesses a few additional distinctive characters, and may be briefly described as follows:—Colour, creamy-white; anal segment or tail-end of body suffused with dark-grey, blue-black, or brown, due to the internal presence and varying colour of the soil being ingested showing through its thin semi-transparent skin. Head, brownish-yellow, edges of "jaws" blackish, shield-like plate on upper surface of first segment adjoining head, light yellow. Body clothed with a few rather long light reddish hairs. Length of body  $2\frac{1}{2}$  inches; across doubled-up position  $1\frac{1}{4}$  inches. (See life-size photo. of third-stage grub on page 10.)

#### How to Identify this Grub in a Few Seconds.

On the lower surface of its last body segment will be seen two central parallel rows of small short reddish spines (about twenty-four in each row), which are partly surrounded by numerous longer scattered bristles. (See illustration on page 10.)

In addition to this curiously arranged vestiture, the width across the head in grubs of the third instar is invariably three-eighths of an inch (never more or less).

The only other root-eating grubs likely to be noticed by growers associated with those of the Greyback, although naturally of somewhat similar shape and colour, happen to be of a darker shade of yellow, and also exhibit entirely different arrangements of the bristles occurring on the last body segment.

#### Nature of Damage to Roots and Cane Sticks.

Some of our growers believe long continued dry weather to be mainly responsible for severe grub damage; their assumption being that during such periods juicy cane roots are liable to be devoured for the sake of the moisture they contain.

As a matter of fact our Greyback cockchafer, although habitually extracting organic matter from soil ingested by it for such purpose, and also consuming a small amount of humus, happens to have a decided liking for living vegetable tissue. Hence its partiality for the succulent roots of sugar-cane, blady grass, &c., and its fondness for English potatoes which are often hollowed out by this cane pest, a single large third-stage Greyback grub being not uncommonly found comfortably ensconced and apparently quite at home in a cavity eaten by it in the centre of a large tuber. Moreover, this taste for growing vegetable matter, combined possibly with an acquired fondness for sugar, induces these grubs to gnaw large holes into the centre of cane sticks which have attained maturity; this is a form of injury, however, which can be more fittingly discussed in next month's notes.

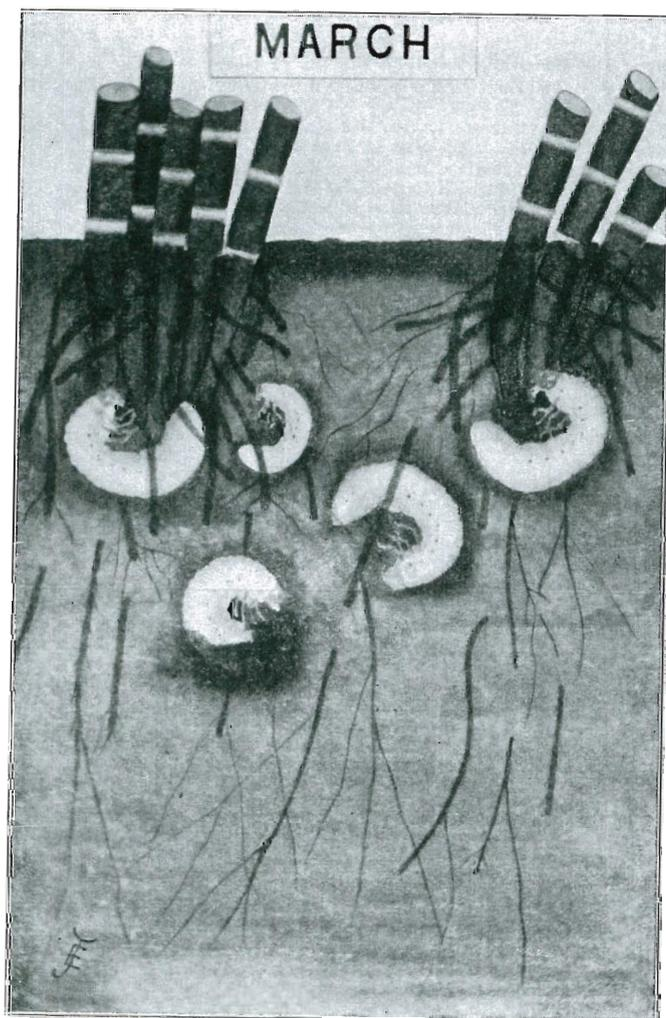

PLATE III.

Grubs of the Greyback Cockchafer under Cane Stools, devouring the larger roots and affecting stability of the Sticks.

The principal damage inflicted by third-stage grubs during March is mainly due to severance and gradual consumption of a large percentage of the main cord-like roots. These succulent roots, varying from one-sixteenth to three-sixteenths of an inch thick, are generally bitten through at points ranging from 4 to 8 inches from ground level, the grub often following up a root as far as the base of the affected stool, devouring the tissue as it proceeds.

The period occupied by grubs of the second-stage of development may be taken as being thirty-eight days, while those of the third-stage live for about sixteen weeks before transforming into pupæ.

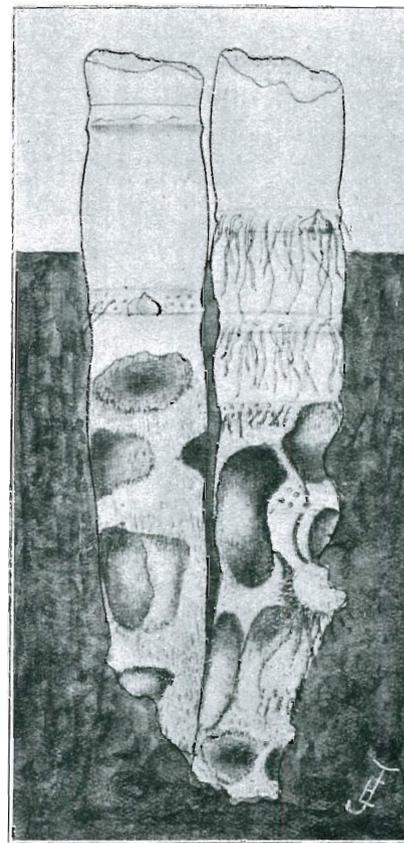

Fig. 4.

Basal portion of cane sticks gnawed by grubs of Greyback cane beetles.

The table given on page 9 indicates the correct dates on which to commence fumigation of grub-infested soil, and applies to beetle emergences taking place on any date between 18th November to 13th January; thus allowing seventy days between appearance of the adult cockchafer to the time when its grubs are large enough to seriously damage the cane.

The plate for March illustrates second and third stage grubs of our greyback beetle destroying the larger roots of cane plants. Such weakened stools, after losing much of their hold of the ground, are liable to be blown over during wet windy weather.

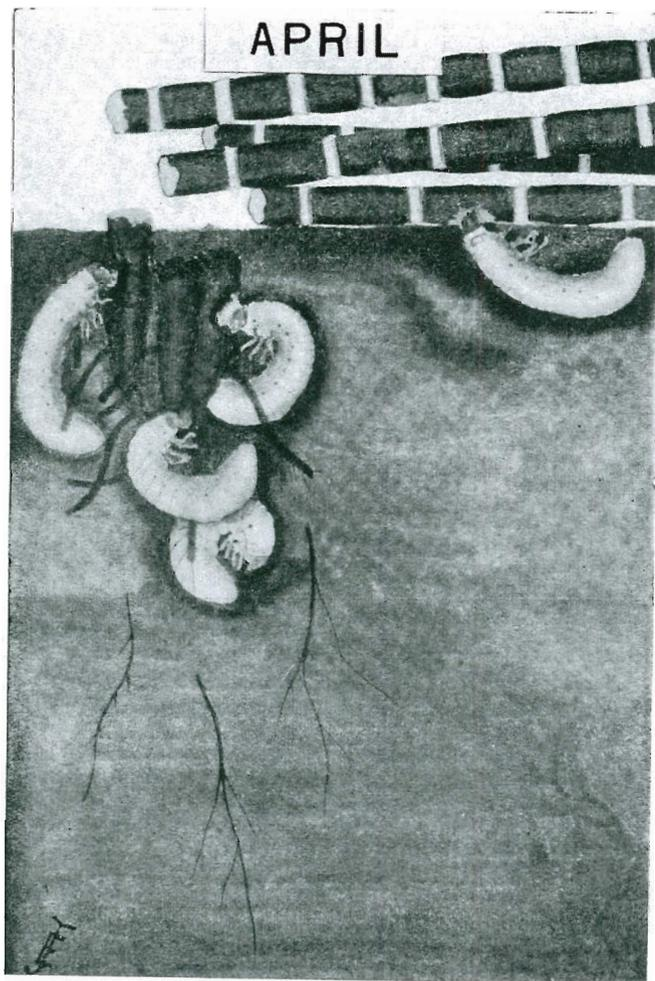

PLATE IV.

Cane sticks gnawed into by Greyback Grubs begin to blow over during April. Third-stage grubs are seen devouring the remains of sticks left in the soil, and gnawing into prostrate canes.

## APRIL.

### GREAT DESTRUCTION OF CANE BY GRUBS OF GREYBACK BEETLE. PREDOMINANCE AND MAXIMUM ACTIVITY OF THIRD-STAGE GRUBS.

THE widely spread damage caused by this formidable insect pest is, perhaps, best seen from the windows of a railway carriage while travelling through or close to grub-infested localities—such as occur, for instance, alongside the Kuranda line between Redlynch and Jungara, or, while journeying to Babinda, between Gordonvale and Deeral.

Amongst an otherwise green expanse of cane-leaves one will at once notice at this time of year large patches of several acres in extent of a uniform dark-brown colour, with marginal edges of same contrasting sharply with the surrounding bright green healthy cane. In such affected areas all the stools have been killed outright, the leaves being dry, twisted, and dead. Again, when viewing distant stretches of cane land from a slight elevation one can pick out these grubby portions by their abnormal colouration of either yellow, reddish-yellow, or dark brown, indicating various degrees of damage.

From five to fifteen or more Greyback grubs may be found under a single stool of such cane, giving an average of at least 70,000 per acre. After suffering a mortality of from 5 to 6 per cent., however, from attacks of parasitic and predaceous insect and other enemies, the survivors eventually transform into pupæ, at depths in the ground varying from 12 to 15 inches, and in due course about 64,000 beetles would emerge from each acre of such infested land. Fifty per cent. of these are usually females, capable of producing collectively about 768,000 eggs, from which grubs hatch a week or so later.

With further reference to this interesting question of the numerical increase of our Greyback beetle, it may be mentioned that in the Cairns district alone, during the 1914 season, no less than 22 tons of these cockchafer were collected in about three weeks. This amount represented fully 8,400,000 greybacks, which are able, under favourable conditions, to destroy 165,000 tons of sugar-cane.

#### Subterranean Movements of the Mature Grub.

After its final change of skin, which denotes commencement of the third stage, the newly moulted grub appears of a pale bluish-white colour, and slightly translucent. At this stage, its new coat being rather soft, it eats very little during the next week or so, the skin meanwhile gradually toughening, becoming more opaque, and finally acquiring the normal yellowish-white colour.

During wet weather in March or April, when at times even light well-drained soils become more or less saturated, these grubs will often work up to the surface in order to obtain sufficient air; and in fields where the trash has been left between the rows after harvesting they occasionally come right out of the soil and lie on top of the ground in semi-darkness, hidden more or less by the litter of dead leaves. Indications of maximum injury to cane are often seen towards the end of April, when the fully-fed grubs, having devoured most of the large roots, eat big holes into or gnaw completely through the basal portions of the cane sticks, gradually bringing them one by one to the ground. Under cover of these fallen canes and leaves, which afford ample overhead protection from sunlight, they soon commence to gnaw deeply into the lower surface of canes lying in close contact with the bare earth, usually preferring the soft cellular tissue of the internodes to harder or less succulent portions. (See plate IV.)

After having finished feeding, about the end of April, the grub has a somewhat plump look, and instead of being creamy-white has darkened to pale-yellow or old-gold colour, and become quite opaque. This change takes place about a week before it starts its downward journey into the subsoil in order to construct a pupal cell.

#### METHODS OF CONTROLLING CANE GRUBS.

##### Fumigation of Grub-Infested Cane Land.

For full directions regarding this control method see pages 9, 10. On farms where the fumigation work has been finished, all hand injectors or other apparatus used should now be thoroughly cleaned and overhauled before being put away until next year.



### Control Effected by Insectivorous Birds.

Our growers would do well to cultivate a regard for the many species of birds which are helping greatly to thin the ranks of this notorious cane insect, both in its beetle and grub conditions. In these enlightened days, when entomologists are so fond of voicing the merits of biological control, we are, perhaps, inclined to dwell too much on the entomological side of this question, and not enough on the advantages to be derived from a closer study of our insect-eating birds and their habits. We must not forget that the services rendered by birds in helping to maintain what is known as the balance of nature cannot be too highly valued by the man on the land.

Incredible as it may seem, one occasionally hears reports of the shooting of ibis and other grub-eating birds for food. Such foolish slaughter, if continued, must eventually lead to several of these feathered friends avoiding the neighbourhood of canefields and feeding elsewhere. About fifteen years ago it was not unusual to see flocks of the Straw-necked Ibis in canefields around Gordonvale and Highleigh picking up grubs behind the plough, but now only one or two specimens are noticed at work in a field, while in some localities this valuable bird appears to have disappeared altogether. The areas proclaimed as bird sanctuaries which chiefly concern residents around Cairns are:—The Shires of Cairns and Barron, the Bellenden Ker Reserve, Kuranda (Mona Mona Mission), and Lake Barrine Reserve.

Amongst the list of 123 birds which are protected during the whole of the year throughout Queensland, the following render more or less important services in our canefields:—(1) Straw-necked Ibis; (2) White Ibis; (3) Pewee or Mud Lark; (4) Indian Mynah; (5) Leatherhead; (6) Laughing Jackass; (7) Fig Bird; (8) Blue Jay; (9) Australian Bee Eater; (10) Black and White Fantail; (11) Black-faced Cuckoo Shrike; (12) Pallid Cuckoo.

### Insect Enemies of Greyback Grubs.

Our two common species of "Digger Wasps" may be considered responsible for a mortality of from 5 to 8 per cent. of second and third stage grubs. Being indigenous insects, however, their increase is effectually controlled by hyper-parasitic enemies, of which the principal are certain flies and a feather-horn beetle.

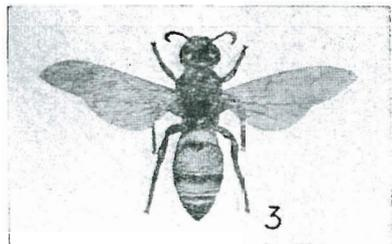

Fig. 5.  
Digger-Wasp Parasite of Cane Grubs.



Fig. 6.  
Maggot of Parasite sucking  
cane grub.

Other predaceous enemies helping to check the activities of greyback grubs include two or more species of robber flies and one of click beetles, the larvæ of which attack them in the soil, puncturing and sucking their life juices.

Species of carnivorous ground beetles and ants doubtless destroy a small percentage of these grubs; while during abnormally wet seasons many succumb to the insidious attacks of insect-attacking fungi and bacterial diseases.

In addition to the above-mentioned enemies, the common Bandicoot and other small native marsupials probably account for a minor percentage of grubs, whenever these chance to occur plentifully, or while they are feeding close to the surface, as often happens during very wet weather.

The plate for April illustrates cane sticks which have fallen, after being nearly eaten through by grubs; this may happen as a result of windy weather, or from the canes having been gnawed completely through laterally.

Four third-stage grubs are shown in the act of finishing off the basal portions of canes which still remain in the ground; while another grub is engaged in eating into an internode of a stick resting on the surface soil.

## MAY.

### COMPLETE DESTRUCTION OF CANE STOOLS BY MATURE GRUBS. GRUBS COMMENCE TUNNELLING DOWN TO CONSTRUCT PUPAL CELLS.

**D**URING the earlier weeks of this month greyback grubs can still be found under stools which they have totally destroyed, busily engaged in devouring the underground basal portions of any remaining sticks, while should the crop be plant-cane the sets also are usually attacked and more or less hollowed out (see Fig. 7). Towards the end of May the full extent of the damage wrought in our canefields by this cane beetle becomes apparent. The percentage of such injury is generally greatest on deep soils of a light, friable character, such as occur, for instance, at the Greenhill Estate, near Hambleton, where the ground is of volcanic origin, or on much of the so-called high lands met with in the Cairns and Babinda districts.

With regard to the economic status of this pest, it may be mentioned here that, unlike several closely related beetles occurring in other countries the grubs of which inflict maximum damage to roots of cane and other plants at intervals of from two to three years apart, the complete life-cycle of the Greyback cockchafer (from laying of the eggs to appearance of adult beetles) occupies a period of only twelve months; so that we are compelled to combat the ravages of its grubs every year.

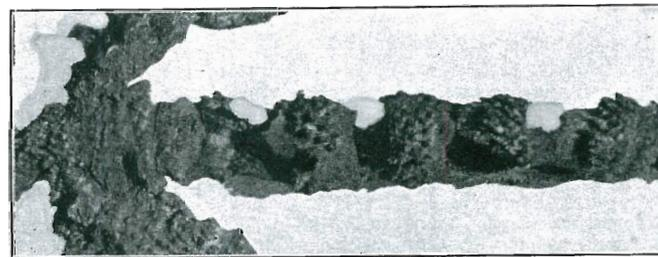

Fig. 7.  
Portion of an old Cane Set badly eaten into by Grubs of the  
Greyback Cockchafer. (About one-third natural size.)

It is probably to this fact, coupled with the large size, voracity, and long continuance of the grub condition, that we must attribute those capabilities for destruction which during seasons of normal rainfall have enabled this insect to obtain first place amongst our pests of sugar-cane. Being, moreover, an indigenous species, it naturally proves very difficult to cope with, seeing that much of our acreage under such crop is more or less surrounded by virgin scrub or forest country, comprising enormous tracts of land over which this native insect continues to breed and multiply as of old, and from which it may extend its range of flight to adjoining cultivated areas.

### Attitude of Canegrowers Towards Fumigation.

On selections where only one or two blocks happen to be lightly grub-infested many farmers prefer to chance results, rather than incur the expense of fumigating their land.

In such cases the element of chance proves more or less attractive, especially on farms where certain fields of early-planted cane are nearing maturity, and there appears a possibility of obtaining sufficient rain to enable the stools to replace any roots being eaten, and of maintaining an upright position until commencement of the crushing season.

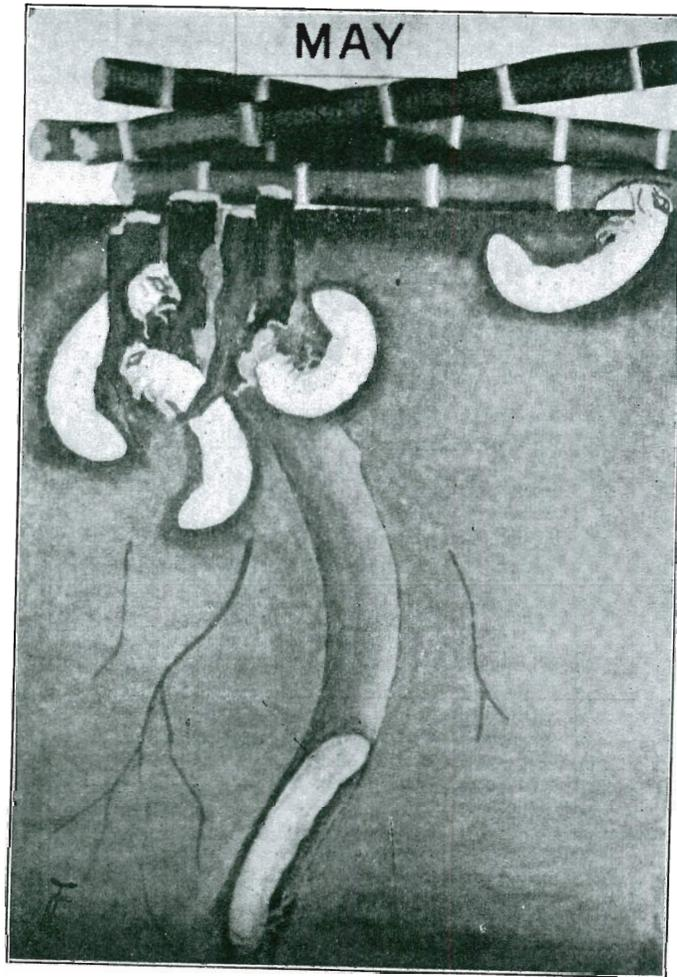

PLATE V.

Cane Sticks eaten out of the ground by Grubs of the Greyback Cockchafer. A fully matured grub is seen tunnelling downwards to construct its pupal cell.

In cases of heavy infestation (an average of ten or more grubs per stool) the future of such crops should never be left to chance, and remedial treatment then becomes imperative. One hears much talk about the cost of fumigants and their being too expensive for use against cane grubs. Such opinions, however, generally come from those who have not given them an adequate trial; those who have done so being, on the contrary, enthusiastic in praise of this form of grub control. Certainly, a grower who suffers losses each season cannot afford to disregard the merits of soil fumigation. Let us suppose, for instance, that he has a crop estimated to yield 25 tons per acre. Would he not be wise to sacrifice five of them in order to make sure of harvesting 20 tons? The 5 tons would pay for the expense of fumigating the acre in question, and not only ensure him a return of 20 tons of cane, but also a crop of ratoons for the following season. On the other hand, by neglecting to fumigate he runs a risk of losing the entire 25 tons and incurring the additional expense of replanting the acre, to say nothing of the cost of cane sets for planting this acre twice over, and the loss of much valuable time.

#### Tenacity of Life in Cane Grubs.

During our wet season the cane on low-lying river flats is sometimes completely submerged. In the event of such crops remaining covered for a couple of days, 75 per cent. or more of the grubs present would succumb to the immersion. In this connection it will be of interest to mention the following experiment:—Full-sized grubs were placed singly in glass test tubes containing rain water, in which, after struggling a few seconds, they sank to the bottom. About an hour later all motion had ceased, and they lay in doubled-up position with legs widely extended. Grubs taken out of the water after intervals of five and a-half, twenty-six, and thirty-two hours' submergence ultimately recovered, while those subjected to forty hours' immersion did not revive.

In repeating this experiment grubs were found to recover from a submergence of forty-one hours; but others, although regaining slight movement after forty-seven hours under water, did not live more than three days. Again, others subjected to sixty-six hours' immersion continued motionless for a time, and then started to decompose.



Fig. 8.

View of Portion of Cane Crop devastated by Grubs of the Greyback Cane-beetle.

#### Common-sense Control of Grubs.

Economic entomologists the world over have long realised the value of systematically collecting the various injurious species of root-eating grubs. In Porto Rico, for example, this method has proved very successful, and is considered to be one of the best ways of preventing such insect pests from increasing. Similarly, in cane-growing districts of Queensland it has yielded good results in the past and is still being followed up with advantage in various centres. The method usually adopted consists in picking up the grubs from behind ploughs and in collecting them from under trash or other debris whenever possible.

**Grubs Commence Pupating.**

Towards the end of this month the fully-developed grub tunnels to a depth of from 18 to 24 inches, where it prepares a cavity in the subsoil to undergo its slow change to the winged adult or beetle. The period of pupation extends from July to September, reaching its completion towards the end of the latter month, by which time greybacks will have practically disappeared, and when digging or ploughing deeply one finds only pupæ of this beetle. These lie quietly in their smooth-walled cells in horizontal position, and if touched lightly will generally wriggle the abdominal portion of the body.

Details regarding the pupal state of our Greyback cane beetle will be described under the month of August.

The plate for May shows a third-stage mature grub tunnelling downwards to pupate, while three others are engaged in devouring the basal remains of ruined cane sticks; one is on the surface gnawing a fallen cane.

**JUNE.****MOST OF THE GRUBS PREPARING TO TRANSFORM INTO PUPÆ.  
INFLUENCE OF MOISTURE ON FINAL POSITION OF THE PUPA.**

**B**Y referring to the accompanying plate it will be noted that during this month a few grubs—derived from eggs laid by beetles belonging to secondary broods (which occurred during late December or in January) still linger in the surface soil subsisting on cane butts. By June, however, most of the damage has been done, 80 per cent. or more of the grubs having ceased feeding and gone below to transform to the pupa or chrysalis condition.

**Behaviour of Grubs while Preparing to Pupate.**

Shortly before tunnelling downwards to change into the next life-cycle stage, the mature grub, which by this time has become quite opaque, assumes a brownish-yellow colour.

Having formed a pupal or resting cell and ejected all extraneous earthy matter from its body the entire grub, as it lies in the ground awaiting transformation, is of uniform colour and presents a somewhat shrunken appearance, the body having now lost its characteristic U-shaped form. When transformation finally takes place its dry-looking yellow skin suddenly splits lengthwise near the head and is gradually pushed or worked off by the underlying pupa; this is accomplished by certain wriggling movements which are continued until the skin becomes slowly detached and is passed backwards to lie as a small crumpled-up pellet at one end of the cell.

It should be remembered that grubs of our Greyback beetle usually pupate directly beneath the line of damaged stools, where the ground has remained practically undisturbed for one or more growing seasons. The care exercised by Nature for the preservation of this particular cane-beetle is well shown by the complete isolation of its pupa, which inhabits a specially-prepared subterranean chamber, the smooth puddled walls of which effectually exclude small insect enemies, and while serving to maintain uniform body-moisture also prevent possible injury to the pupa by heavy flood rains.

The depth at which pupæ of the Greyback are found to occur may vary from 6 to 15 or more inches, depending largely on the mechanical composition of the soil, its porosity, the degree of moisture present at time of pupation, natural drainage, and the presence or otherwise of aggressive soil-frequenting insect enemies of the grub. The average depth of the cell in light land with a clay or stony subsoil is about 12 inches; while on certain volcanic soils of uniform composition and great depth these pupæ have been found 2 feet or more below the surface. On the other hand, they have been collected from sandy loams at depths varying from 4 to 6 inches.

**Subterranean Parasites of Grubs.**

From April to June a varying percentage of mature Greyback grubs are likely to succumb to the attacks of the well known vegetable parasite "Green Muscardine Fungus." When invaded by this parasite the body of a grub, instead of decomposing in the usual manner after death, retains its ordinary shape, and gradually hardening turns at first white and then an olive-green colour. At this stage the body, being filled with the "roots" of the fungus, becomes mummified and can be broken into pieces as though made of dry cheese. The green appearance of these grubs is due to the presence of microscopic chains of spores arranged in prismatic masses incrusting the body, and being in reality the fruit or seed of this parasite. (See illustration.) If wishing to make the best use of such spore-laden grubs, they should be collected by the grower when noticed in plough-furrows, crushed into powder, and thoroughly mixed with about one-thousand times the quantity of moist finely-sifted soil, rich in organic matter. This should be sieved and then placed in a tightly-closed tin canister until used, to keep the soil from becoming too dry. When planting any area of land known to be liable to grub-infestation a little of this spore-laden soil may be sprinkled at intervals of 2 or 3 feet as thinly as possible in the furrows just ahead of the planter.

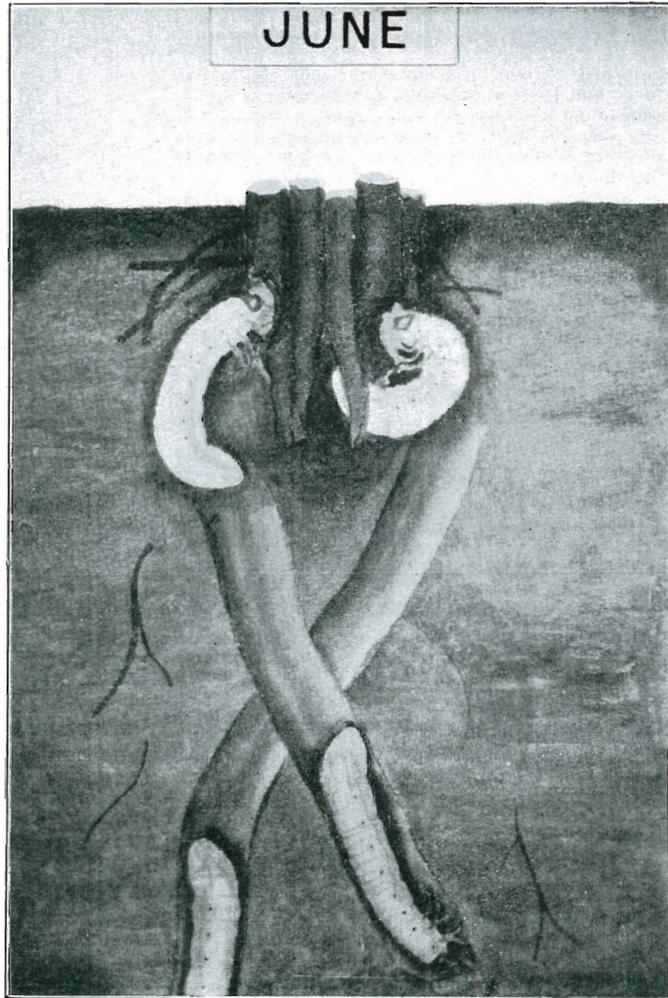

PLATE VI.

Grubs of the Greyback Cane Beetle tunnelling into the ground to transform into the pupal condition. Other grubs still feeding on basal portions of cane sticks.

Another parasite which usually causes heavy mortality during seasons when these grubs chance to occur in great numbers is a species of bacterium. Grubs invaded by this bacterium exhibit black blotches on the sides, especially around the spiracles, which are quickly followed by rotting off of one or more of the joints of the legs. A day or so later the entire body blackens and liquefies internally, quickly decomposing into an evil-smelling mass. Abnormally wet conditions prove highly favourable to development of this bacterial disease, which generally destroys its victim about five days after infection.

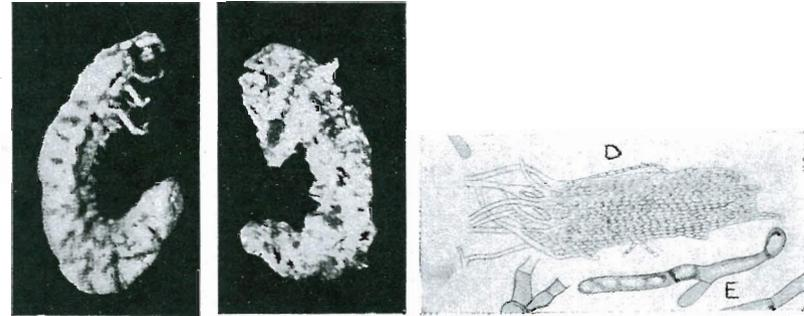

Fig. 9.

Grubs of Greyback Cockchafer killed by Green Muscardine Fungus; showing *mid* and *final* stages of development. (Natural size.)

Fig. 10.

D. A prismatic mass of spores. X 160.  
E. Spores germinating, X about 700.

#### Influence of Moisture on Depth of Pupæ.

When the period of transition from grub to pupa chances to commence just after heavy rain has fallen (at the end of June or early in July), many of these grubs are induced to pupate unusually near the surface. In such years, therefore, when sufficiently moist conditions are encountered by them at a depth of about 8 inches, pupation in certain classes of land is liable to take place at levels in the soil varying from 7 to 9 inches below the ground. Common-sense control methods can be profitably undertaken during such seasons, and growers are advised in such favourable years to plough up their grub-infested blocks of cane to a depth of from 9 to 12 inches in August or September, and so combine with ordinary farm cultivation the destruction also of thousands of grey-back pupæ.

Similar work when carried out in October in such seasons will unearth and bring into the plough-furrows numerous adult specimens of this cockchafer beetle, which being immature generally succumb to the untimely exposure to the light and hot sunshine. In addition, however, to this control exercised by man, prolonged dry weather may be experienced in such years during July and August, in which case pupæ lying at depths of 6 or 8 inches in light, porous soils are likely to suffer from lack of sufficient moisture. Should drought conditions continue until the middle of December these unfortunately situated pupæ would naturally be the first to perish.

A full description of the pupa will be given in the July notes on this beetle, together with a discussion of the possibilities of its control by means of artificial methods. The downward journey of grubs into the soil in order to construct pupal cells is illustrated in the plate given this month. The small remnant still feeding will follow them a few days later.

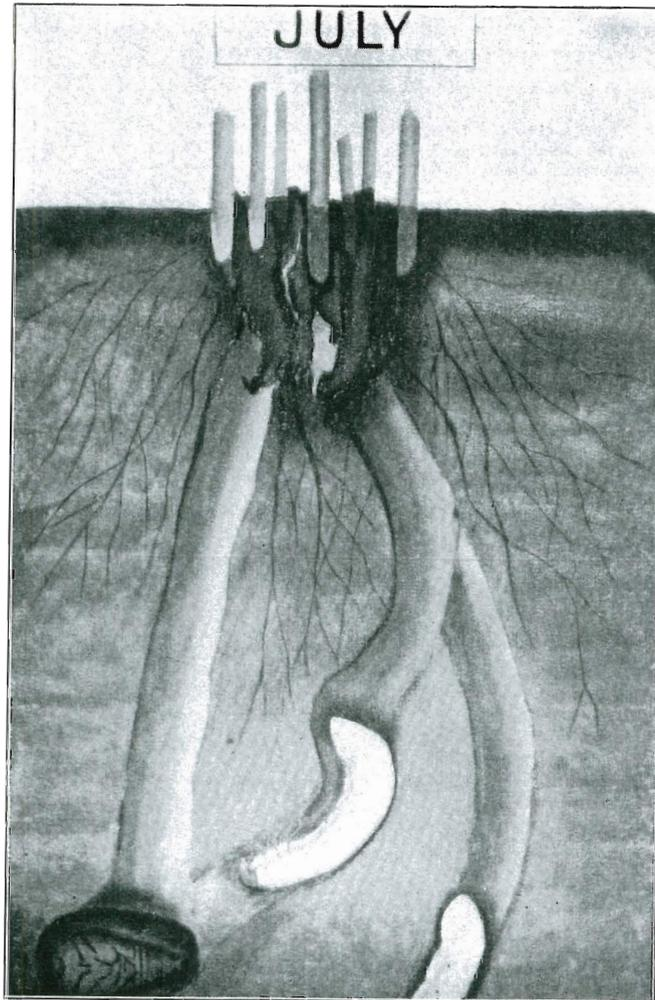

PLATE VII.

Grubs of the Greyback Cockchafer tunnelling into the ground to transform into pupæ.

## JULY.

**COMMENCEMENT OF THE PUPAL LIFE-CYCLE STAGE OF GREYBACK.  
END OF PERIOD OF ACTIVITY OF GRUBS OF THE GREYBACK.  
MONTH FOR ORDERING SUPPLIES OF FUMIGANTS FROM THE MILL.**

**T**HE coming of July usually denotes cessation of the larval phase of this cane beetle, and the consequent final departure of all third-stage fully-grown grubs from among the cane roots to various depths below basal portions of affected stools in order to assume the pupal stage of growth.

### Appearance and Coloration of the Pupa.

The pupa of the Greyback is quite the largest of those occurring in plough furrows, full-sized specimens being  $1\frac{1}{2}$  inches long by nearly  $\frac{3}{4}$  of an inch across the widest portion, as shown in the illustration (Fig. 11). Its general colour is reddish-yellow, which gradually darkens as final transformation into the adult beetle approaches.

### Ordering Grub Fumigants for the Coming Season.

Early this month canegrowers should place their orders for carbon bisulphide or paradichlorobenzene with the accountant of the sugar-mill to which their cane is assigned, the quantities asked for depending, of course, in each case on the number of acres to be treated on individual farms. From £8 to £9 per acre, including labour, is usually allowed for the cost of fumigating a crop. The price of Danks' hand injector is about £7 5s., plus insurance, packing, &c.; if taken care of these injectors will last for years and give good service.

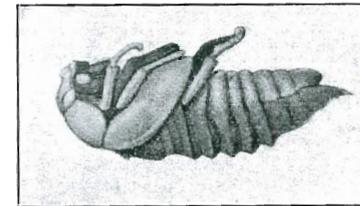

Fig. 11.

Pupa of Greyback Cockchafer. (Natural size.)

The plate for July indicates Greyback grubs tunnelling downwards to transform into pupæ, one of which is shown at the corner of the plate. The cane stool above is throwing weak young ratoon shoots.

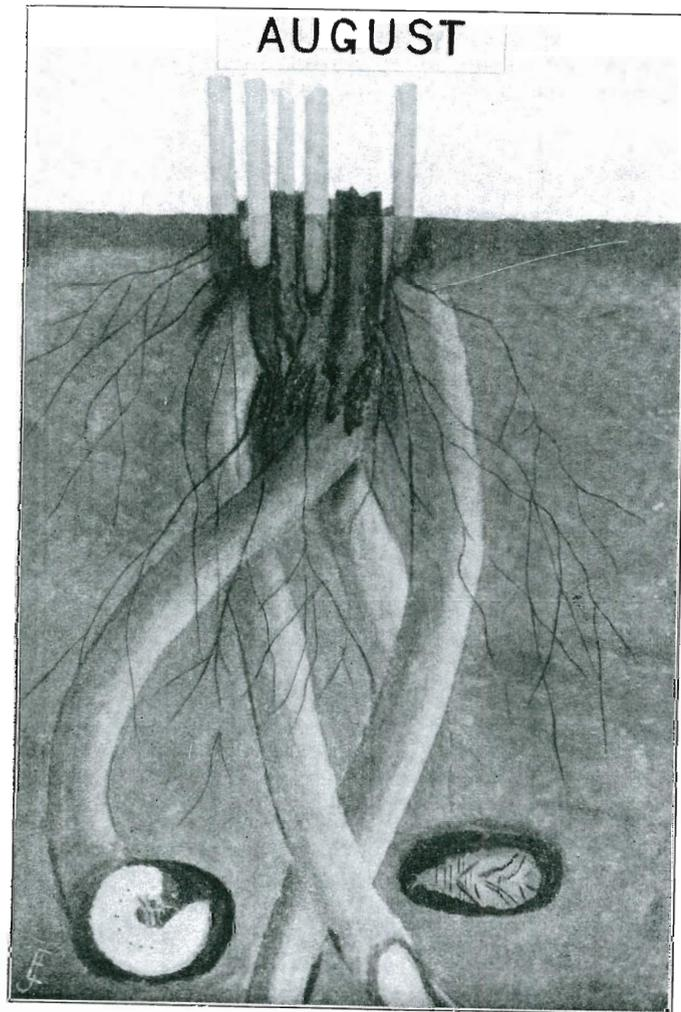

PLATE VIII.

Showing pupation of grubs of the Greyback Cane Beetle and a pupa of same in its resting or pupal chamber.

## AUGUST.

**ECONOMIC SIGNIFICANCE OF THE PUPAL STAGE OF DEVELOPMENT.  
OCCURRENCE OF BOTH GRUBS AND PUPÆ IN SUBTERRANEAN CELLS.  
TRANSFORMATION OF PUPÆ TO THE WINGED BEETLE CONDITION.**

**A**UGUST marks the commencement of a decided lull in the activity of this cane insect, which for the time being has lapsed into a condition of torpidity and disappeared from view. Its grubs, after forming their pupal cells, can now be found either lying in them with shrunken straightened body, or awaiting in the form of pupæ that call to a wider sphere of action than that experienced by the grub or its mummy-like pupa.

At this time of the year growers should make a careful inspection of affected areas, to determine if possible the reason for such invasion of this cane beetle. In the event of a belt or clump of timber containing food plants of the beetle chancing to occur in the midst of a plantation or to separate two adjacent fields and to lie in a south-westerly situation, within a mile from the southern headland, such trees should be cut down.

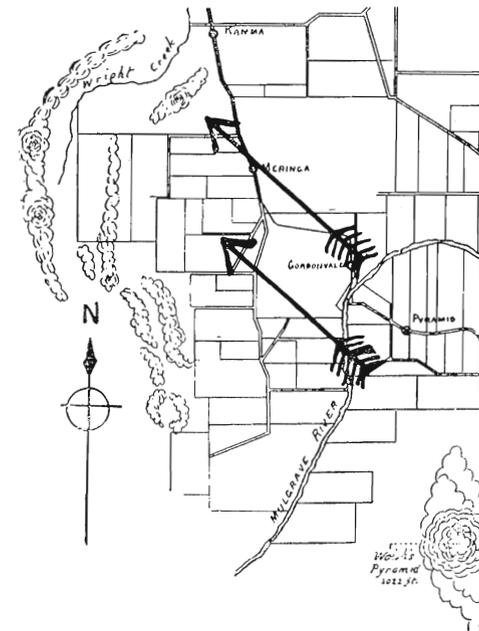

Fig. 12.

A small pocket of cane land near Meringa partially encircled by mountainous country. The arrows show direction of trade wind, and of migrating Greyback cockchafer chancing to travel with same.

Similarly, when either of the opposite sides of an area of cane land happens to run in a north-easterly direction and to be closely bounded by forest country, it often becomes advisable to cut out all feeding trees growing near such headlands

to a distance of at least half a mile from the nearest rows of cane. On the other hand, when the southern edge of a canefield is bounded closely by forest land extending far to the southward, it is *not* advisable to clear a belt of timber back from such headlands, or to cut down the feeding trees.

Should grubs occur over an area of caneland chancing to be more or less surrounded on all quarters except the south by timbered mountain ranges, destruction of the food plants of this beetle would, if practicable, not only entail considerable labour and expense, but be likely in many cases to prove ineffectual as a control measure. Such cul-de-sacs or large pockets usually become grub-infested in the first place as a result of the arrival of greybacks migrating from the south-east which are forced to come to rest finally upon timber fringing the basal portions of these ranges. Finding the situation favourable for breeding purposes, and that further progression towards the north, east, and west is obstructed by mountainous country, they generally become established in such localities and regularly damage the cane each season.

In the case of permanent infestations of this kind, the best plan of procedure would be to try to prevent excessive multiplication of these beetles by collecting them during each fighting period either from native food plants or from trap-trees grown for such purpose, and by picking up the grubs during the course of cultural operations. By exercising common-sense methods of this kind on such cane areas it should be possible to reduce the grub pest to harmless proportions, seeing that the fields are practically closed from invasion from all quarters but the south.

#### Economic Significance of the Pupal Period.

Apparently the most important phase in the life-cycle of our greyback cockchafer from an economic point of view is that of its pupal condition, which happens to be passed underground at depths varying from 6 to 15 or more inches. Although occupying a position so well calculated to exclude possibility of attack from predaceous insects or other enemies, these beetles, after transforming to the winged state about six weeks later, unfortunately find themselves practically imprisoned in their subterranean cells, from which escape is often impossible until the surrounding hard dry soil becomes sufficiently softened by heavy rain to enable them to reach the surface. Now, it is all important that, just before and for some time after pupation of these grubs in June or July, the rainfall should continue to be normal throughout a period of five months (June to October) in order that such transformation may take place at the proper depth, and the soil remain moist until commencement of the fighting season. In the event of abnormally dry conditions prevailing during these months, coupled with a precipitation far below the average throughout the preceding period of January to May, a check to the activities of this species must assuredly follow.

Should such adverse climatic conditions, however, be continued through November and December, the check sustained is likely to be very severe, causing enormous numbers of these cockchafers to perish hopelessly in their underground pupal chambers.

It appears, therefore, from available data obtained during a period of about thirty years that heavy annual rainfalls are not, as some growers imagine, invariably followed by serious grub infestation; such outbreaks of this pest being usually determined, as pointed out above, by the quantity of rain chancing to fall during what should be known as the *critical period*, occupied by its pupal and early beetle conditions.

#### Change from Pupa to Beetle.

During the subterranean life of this insect profound physiological changes occur. While the outer body-case of the future beetle is gradually hardening, the entire interior anatomy of the pupa, including muscular, nervous, and other systems, are becoming liquefied; this fluid matter giving rise later on to totally different structure, designed to meet conditions to be encountered during the course of its winged or perfect state.

The diagrammatic sketch for August indicates the downward trend of tunnels made by mature fully-fed grubs after forsaking the cane roots. At the bottom of plate a pupa and a grub nearing transformation are lying in cells; while the anal segment of one of the latter, seeking lower depths, is just disappearing.

## SEPTEMBER.

### OVERHAULING AND REPAIRING HAND-INJECTOR:

#### HOW TO USE SAME.

#### PREDOMINANCE OF THE PUPA STAGE OF GREYBACK COCKCHAFER.

**T**HE month of September is essentially associated with the pupal condition of this cockchafer, and it will be found that 90 per cent. or more of the specimens unearthed during the course of deep ploughing or breaking up of old cane lands are examples of this curious stage in the life of our greyback. The pupa of a beetle corresponds to the co-called chrysalis form in butterflies, representing a period when locomotion and feeding ceases altogether for a time, while the life juices of grub or caterpillar undergo a marvellous transformation into what has been termed the perfect state of an insect.

#### Construction of the Hand-injector.

The appliance being used in North Queensland for fumigating cane grubs is an injector manufactured by John Danks and Son, of Melbourne and Sydney.

The accompanying drawing shows its internal arrangement and the method employed for ejecting from the spear varying quantities of liquid fumigant. Special attention should be given to the position of the different washers, indicated in black, as these have to be renewed occasionally when worn out. In this connection the following advice from the Assistant Entomologist at Meringa Experiment Station, Mr. J. H. Buzacott, regarding possible sources of such trouble and how to deal with them, will be found invaluable, and should be carefully studied:—

“1. Washers L and V sometimes require replacing. This is denoted by external leaks at L or V.

“2. Main pump washer G frequently requires tightening or replacing. To tighten, screw up nut J after first unscrewing compression chamber assembly from tank assembly. To replace washer, remove nut J and pull out old washer with a piece of wire. Wind about 2 inches of a narrow strip of raw hide round plunger, and force into cavity with a wire. Then screw nut J back into place and tighten gently. If this washer requires tightening or renewing, it is shown by weak pressure of injection.

“3. Ball valve seat H sometimes has dirt on it, and this also causes weak injection. The remedy is to clean the valve well.

“4. If the pump leaks at the bottom hole when the spring plunger is up, the cause is a faulty washer X, a bent compression valve stem R, or insufficient tension on valve spring Q, owing to nut Y not being screwed up sufficiently tight. To replace washer X, unscrew spear from compression chamber assembly at V, take off nut Y and remove old washer. Cut new leather washer to fit in recess in Y and with central hole to fit on stem R. Rescrew Y on R and adjust tension so valve does not leak. If a bent valve stem R is the trouble, the whole valve assembly must be screwed out by means of a special box spanner, which fits over squared portion U. The valve stem is then removed and straightened. When replacing valve assembly the washer S must be in good order.

“5. Should it be found difficult to press in the plunger of the injector, it will probably be due to the delivery passage Z being blocked. This may be freed by passing a thin wire through it.

“6. It sometimes happens that the main spring will not return the plunger to its proper position. Usually this is caused by the pin retaining the brass collar about half way up the plunger having sheared, thereby releasing tension on the spring. The old pin must be driven out and the collar held in its correct position by means of a new steel pin riveted in position. A broken main spring or a bent plunger can cause the same effect. For the former a new spring is necessary, and to cure the latter it must be removed and straightened.

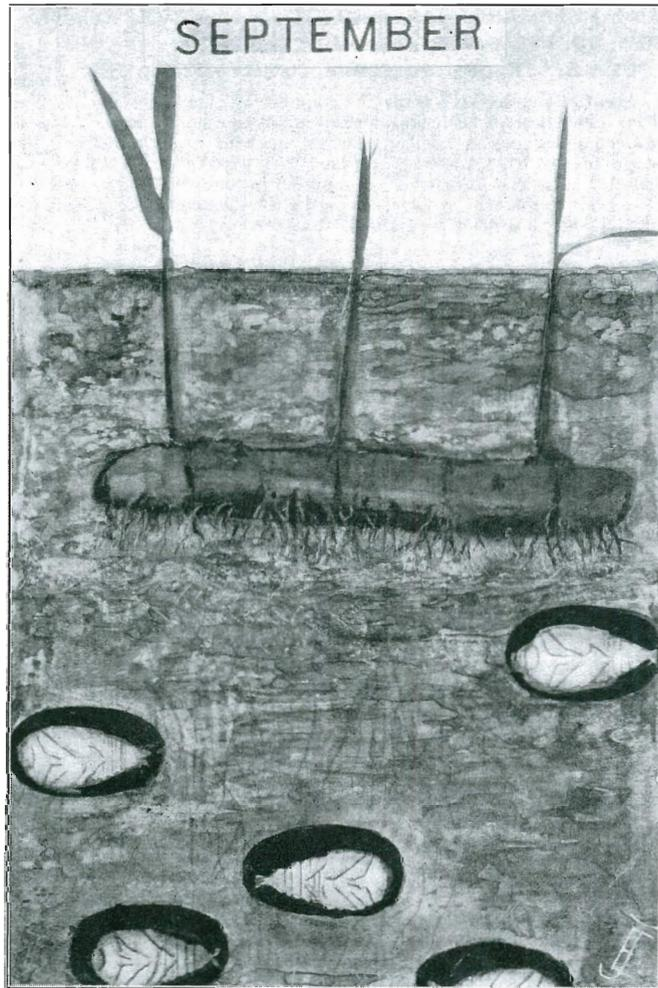

PLATE IX.

Pupae of Greyback Canebeetle lying under cane sett awaiting transformation into beetles (about half natural size).

*Note.*—An injector will not work correctly if the hole in the stopper of the tank is blocked up. Some operators place pieces of grass in this vent to prevent splashing, but if this is done the instrument will not deliver the correct dosage, owing to the vacuum created within the tank preventing the liquid from running freely through passages E and F.

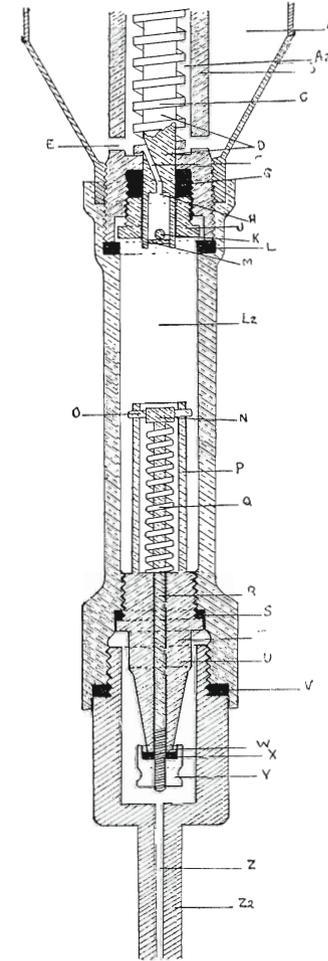

Fig. 13.

Internal mechanism of Danks' Hand-Injector, showing positions of washers, springs, valves, delivery passage, &c.



## KEY TO DIAGRAM OF DANKS' INJECTOR.

- A. Main liquid container or tank.
- A2. Spring guide chamber.
- B. Main spring guide.
- C. Main spring.
- D. Plunger rod.
- E. Passage between tank and guide chamber.
- F. Passage through plunger rod.
- G. Main pump washer.
- H. Ball valve seat.
- J. Nut retaining pump washer.
- K. Ball valve.
- L. Upper compression chamber washer.
- L2. Compression chamber.
- M. Pin retaining ball valve.
- N. Collar retaining compression valve.
- O. Guide pins.
- P. Compression valve spring guide.
- Q. Compression valve spring.
- R. Compression valve stem.
- S. Compression valve guide washer.
- T. Compression valve guide.
- U. Squared portion for box spanner.
- V. Spear washer.
- W. Valve seat.
- X. Leather valve washer.
- Y. Knurled nut adjusting tension of valve spring.
- Z. Delivery hole or passage.
- Z2. Spear.

**OCTOBER.**

**BEETLES LYING IN PUPAL CELLS ATTAINING STRENGTH FOR FLIGHT.  
PUPÆ DERIVED FROM LATE BROODS OF GRUBS STILL  
OCCUR IN CELLS**

**Make Arrangements for Fumigation Work.**

During October cane farmers should arrange to secure the services later on of reliable men for carrying out the work of fumigating grub-infested land at the proper time. It is needless to state that the chief qualification for this class of field work is conscientiousness, and such desirable men should never be hurried, but allowed time to do the work to their own satisfaction.

**Inspection of Hand-injectors.**

Hand-injectors should now be overhauled, and all washers closely examined. It will be found a good plan to cut a number of duplicates of those washers which are liable to give trouble or get out of order when fumigation work is in full swing, and delays caused by such replacements prove inconvenient and mean loss of valuable time. It would be well to have duplicates on hand of washers G, X, S, L, V. (see illustration of section of hand-injector published in September notes.)

**GREYBACK COCKCHAFERS LYING IN PUPAL CELLS.**

October is the earliest month in which it is possible for a first brood of beetles (primary emergence of the season) to escape from the soil. Such undue appearances, however, rarely happen, two instances only having occurred during the last twenty years. In order to bring about an emergence of this nature, the beetles of the preceding year would need to have taken to wing early in November, and to have assumed the pupal state the following June, under exceptionally favourable climatic conditions.

The life-cycle of the pupa occupies a period of about five weeks, an additional three or four being passed by these beetles in their subterranean pupal chambers. Time is thus afforded for the outer casing of the beetle to become rigid and horny enough to resist contraction of the internal muscles required to operate movements of the powerful legs and wings of the mature cockchafer.

The plate for October shows a little more evidence of movement than was apparent during September, more than 50 per cent. of the beetles having now appeared in their resting cells to complete maturity and await ultimate release when rain has softened the earth overhead. A lately transformed pupa is seen in another chamber, and above that a set carrying cane sticks for next season's crop.

**Trap-trees for Beetles.**

Amongst the various methods of combating Greyback cane-beetles—that of collecting them from suitable trap-trees—deserves serious consideration, and should in certain cases be practised by individual farmers. On selections, for instance, where these cockchafers habitually invade the cane areas from near-lying belts of forest land, a number of such trees could with advantage be planted on headlands nearest to this timbered country. The best tree to use for this purpose is the well-known "weeping fig," which has recently been found to be most attractive of all the various food-plants of the Greyback, and appears to be specially adapted for such control work. It can be grown from seed, from cuttings, root grafts, or layered twigs; and after reaching a height of about 6 ft., rapidly makes a big tree, being very hardy and well suited to tropical conditions.

These figs could be planted about a quarter of a mile apart, starting from corners of the headlands needing protection. When of suitable size, the heads should be pruned in such manner as to induce a low and spreading growth of convenient height for collecting.

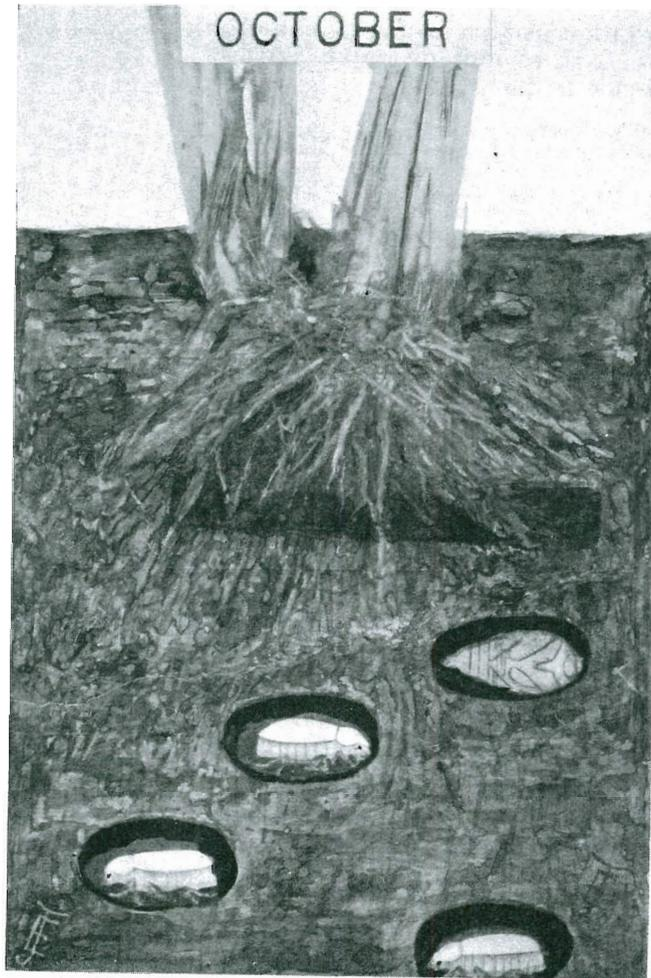

PLATE X.

Greyback Cockchafers in pupal cells waiting for rain to soften the ground and allow them to reach the surface. The fourth cell contains a pupa.

## NOVEMBER.

### FIRST APPEARANCE OF EGGS AND YOUNG GRUBS IN CANEFIELDS. GREYBACK COCKCHAFERS EMERGE FROM THE GROUND THIS MONTH.

Our first heavy rains often fall in November, and in the event of September and October having been dry months a precipitation of 3 or 4 inches is invariably followed by a primary emergence of this beetle pest. If rain comes early in November, but lasts only a few hours, we may expect a secondary emergence later on, after another downpour, either at the end of November or early the following month.

During September the pupae of this cockchafer were mostly in evidence (see Plate IX.); while the month of November is characterised by the occurrence of multitudes of the beetle form of this insect patiently awaiting the coming of rain which will enable them to reach the surface and take to wing. Should dry weather continue, however, throughout November, a certain percentage of Greybacks chancing to occur in light soils of high porosity still manage to escape imprisonment. Such belated specimens are easily distinguished by their dark reddish-brown colour, due to the white body scales having been rubbed off by contact with the hard dry earth during their difficult passage upwards.

#### RECORD OF PAST PRIMARY EMERGENCES OF GREYBACK BEETLES.

Year.	Month.	Year.	Month.
1914	.. .. . 5 December	1924	.. .. . 13 December
1915	.. .. . 11 December	1925	.. .. . 18 November
1916	.. .. . 7 November	1926	.. .. . 18 December
1917	.. .. . 29 October	1927	.. .. . 20 December
1918	.. .. . 15 October	1928	.. .. . 12 November
1919	.. .. . 15 January	1929	.. .. . 19 November
1920	.. .. . 5 November	1930	.. .. . 30 November
1921	.. .. . 2 December	1931	.. .. . 27 December
1922	.. .. . 22 December	1932	.. .. . 15 December
1923	.. .. . 7 December		

It will be seen from the above table that primary emergences of this cockchafer may happen as early as 15th October, or as late as the middle of January. Although November and December are evidently the two principal months for its appearance on the wing, the aerial existence of this cane-beetle occurs most often during December. In those years when "fighting" happens to take place towards the end of the latter month (December), it is worth noting that such conditions are likely to favour subsequent fumigation of its grubs, by curtailing the activities of this pest during such late seasons to a single emergence of the beetles.

#### Factors Influencing Migration of Greyback Beetles.

The natural laws which govern the movements of certain insects are too complex to deal with here, but it may be briefly mentioned that several species, including our Greyback cockchafer, when chancing to multiply abnormally over restricted areas sometimes seek to migrate when possible to fresh fields in order to ensure a wider distribution of eggs and establish their grubs or larvae on different classes of soil, thereby lowering perchance the percentage of mortality caused by insect enemies, or securing greater abundance of food. A local invasion of these beetles which occurred in the Cairns district during 1930 occasioned rather severe damage in the vicinity of Alooomba, the army chancing to come to rest on cane land around Banna. In this case the invasion probably originated either on forest land reserved for a national park in the parishes of Sophia and Bellenden Ker, or in the State forest reserve in Cadgarra. In the former case the line of flight would have taken a south-easterly direction, over country lying between the Mulgrave River and Pyramid Range. It seems more likely, however, that this breakaway originated in the Cadgarra area, in which case the line of flight probably skirted along the

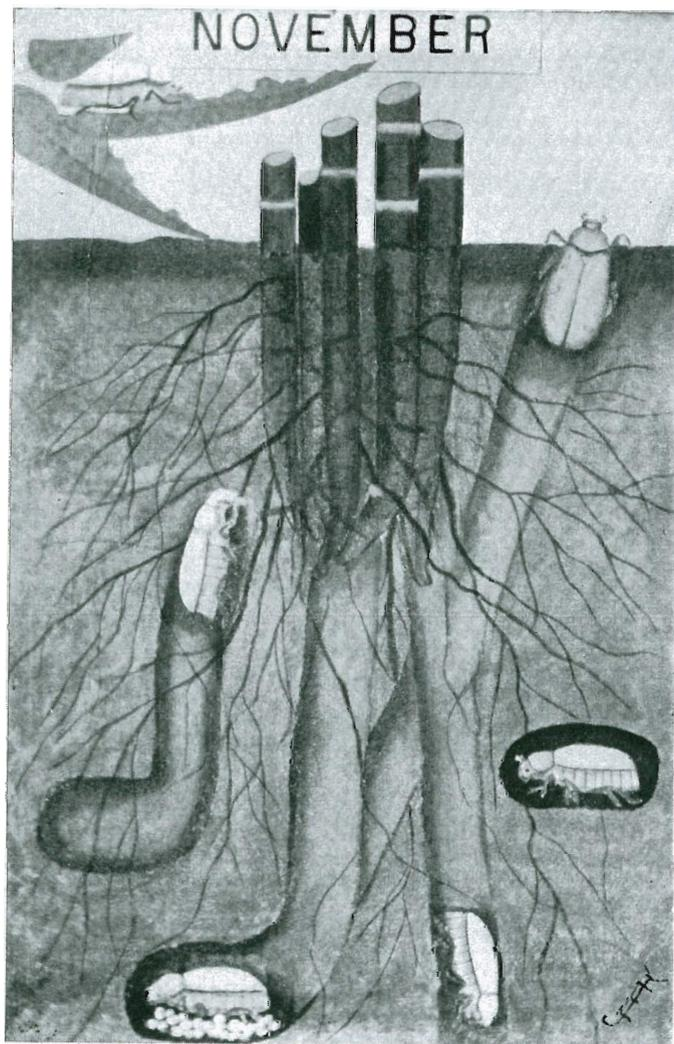

PLATE XI.

Showing activities of the Greyback Beetle about a fortnight after the first heavy fall of rain. Specimens (left to right) (1) escaping to the surface from cell; (2) laying eggs; (3) tunnelling downwards to oviposit; (4) reaching the surface; and (5) not yet ready to emerge from cell.

western slopes of the Pyramid Range. It will be of interest to mention that the grub-infestation of cane lands surrounding the Mulgrave Mill was apparently brought about in the early days by Greybacks that migrated there from extensive breeding grounds lying south from Aloomba, between the Malbon Thompson and Pyramid Ranges. Fully one-third of this tract of country, consisting of about 80 square miles, was at this time uncleared forest land, including much virgin scrub and open country supporting native grasses, &c.

#### Collecting Cane-Beetles from their Food-plants.

In 1914 we collected 22 tons of beetles in the Cairns district, enough to destroy about 165,000 tons of cane.

An example of the usefulness of such work is reported from Mauritius, viz.:—“The number of *Lachnosterna* (cane-beetles) captured in 1919-20 was under 13,000,000, as compared with over 71,000,000 in the previous year, and is the lowest since 1912-13. The figures indicate that a control has been established in those areas in which the infestation originated; it is only in the more recently invaded part of the area that the number of beetles taken is still on the increase. This view is corroborated by the results of surveys for the larvæ.” In this connection it should be mentioned that our canegrowers possessing selections known from past experience to be liable to grub attack, would do well to make arrangements for collecting Greybacks from the foliage of favourite feeding-trees of this pest. (See pages 33, 40.)

#### First Appearance of Eggs in Cane Land.

Oviposition of this beetle may occur at any time during November to January. Its eggs being found most plentifully in December, however, the description of same has been recorded under that month's notes.

The structure of the ovary of a Greyback consists of two ovaries, comprising twelve ovarian tubes, each holding three eggs. Two of these usually develop together in each tube, hence the number 24 that are so often found in egg-chambers. The remaining twelve farthest from the oviducts continue quite small, although subsequently developing about ten days later, and are finally deposited erratically two or more at a time.

The plate for November illustrates the awakening to activity of the first lot of Greyback cockchafers; eggs being laid; beetles emerging from the ground and feeding on eucalyptus leaves.

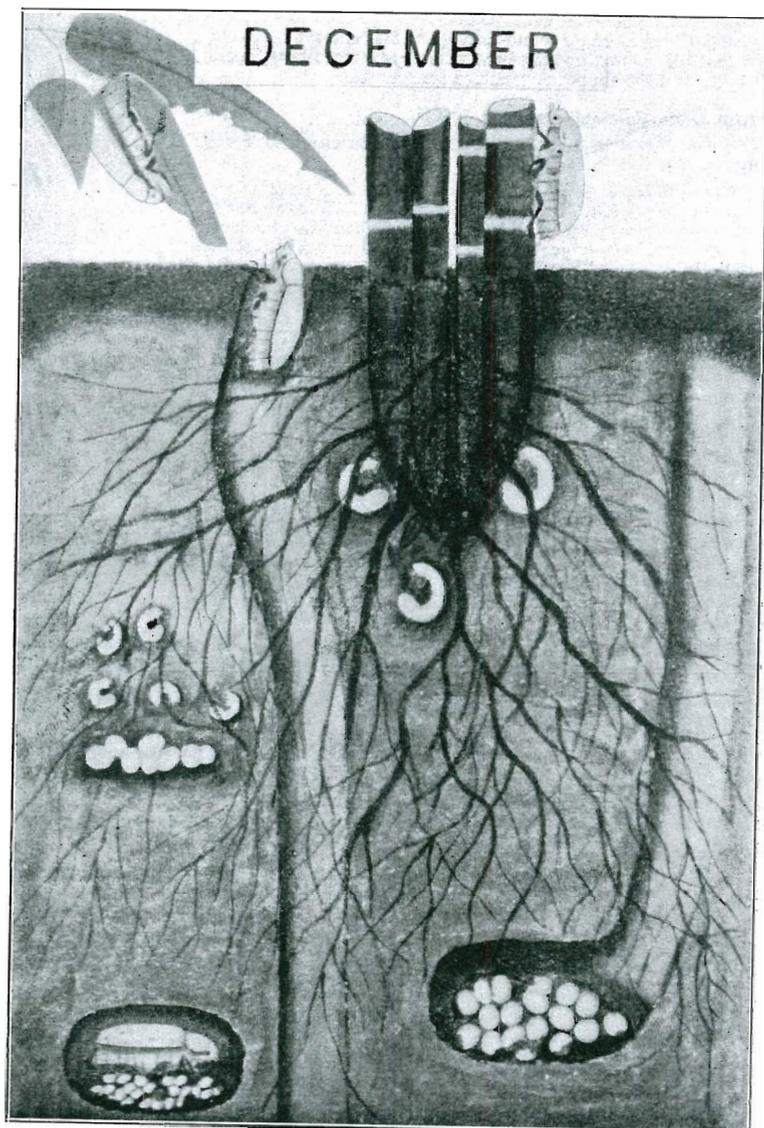

PLATE XII.

Habits of the Greyback Cockchafer Beetle during the month of December.

## DECEMBER.

**FIRST-STAGE GRUBS OF GREYBACK ARE USUALLY IN EVIDENCE. FLIGHTING AND EGG-LAYING PERIOD OF GREYBACK CANE-BEETLE.**

**D**URING December Greyback cane beetles can generally be found on their various feeding trees, such as the Figs and the so-called "Moreton Bay Ash," besides other favourite food plants.

In years when this cane pest chanced to emerge in November its first-stage grubs can be found amongst the fibrous feeding roots of cane in late December.

### HABITS OF THE GREYBACK COCKCHAFFER.

A few hours after a fall of from 3 to 5 inches of rain (which usually occurs towards the end of November or middle of December) the awaiting host of Greybacks, acting under the stimulus of such moisture, start to tunnel upwards through the ground until reaching the top 2 inches of surface soil, where they remain until daylight has given place to semi-darkness.

Emergence occurs about 7.15 p.m., at which time a wave of unrest apparently induces activity in every beetle simultaneously, causing the swarming multitude to crawl excitedly out of the ground on to the surface to extend their now quivering antennae, spread their elytra and large membranous wings, and finally to mount into the air to enter upon their winged or perfect state.

Having exercised their wings for an hour or two, the main body settles amongst twigs and branches of the nearest trees, where copulation takes place the same evening at a height of 15 to 20 feet from the ground, after which they usually fly about again for a time until finding suitable food-plants. During the succeeding ten to fourteen days, while the ovaries are developing, these beetles live a free arboreal life, many hours of daylight, however (from dawn to noon), being passed in a state of torpidity or slumber.

If disturbed at such times they drop hastily to the ground, offering little or no signs of life, and refusing to crawl or fly away when handled.

While clinging to the leaves in this passive sleepily condition many specimens are attacked by parasitic insect enemies in the shape of Tachinid flies, three species of which manage to affix eggs to their bodies or deposit tiny maggots on them, which quickly wriggling out of sight bore into the living tissues.

Being settled on the trees, fully exposed to all weathers, these beetles are naturally more or less affected by abnormal degrees of temperature. For example, on days when the maximum shade heat reaches 95 to 100 degrees Fahr., and the wind happens to be north-west, they soon exhibit signs of restlessness, and at length, becoming fully awakened, begin to crawl quickly about in search of cooler positions.

On such days the Greybacks in a large feeding tree will, as a last resource, often fly in a body to the shaded or sheltered side of the trunk and settle there side by side in mass formation.

Duration of the usual evening flight is greatly influenced also by temperature, humidity, and illumination.

On warm dark nights following showery days these cockchafers become exceedingly active, often remaining on the wing several hours and being freely attracted to artificial lights. When no rain has fallen for a week, however, and the surface soil becomes very dry, they will often refuse to fly at all at the usual time, or else take to wing for a few minutes only. Again, on moonlight nights, greybacks are little in evidence, although should the atmosphere chance to be moist, and the sky more or less cloudy, migration may occasionally take place.

The period of oviposition commences about a fortnight after emergence of beetles from the soil. Plantations are then invaded at night-time by egg-laden females coming from food-plants near at hand, which upon alighting on the ground

against the base of a cane stool tunnel underneath it to the depth of a foot or more, and deposit their eggs in a roughly-formed ovate cavity or chamber measuring about  $1\frac{1}{2}$  inch by 1 inch.

Each beetle is able to lay thirty-six eggs of a creamy-yellow colour, which just before hatching swell to nearly  $\frac{1}{4}$  inch in diameter. About ten days after oviposition the tiny newly-hatched grubs make their appearance, and tunnelling upwards ultimately reach and take up their quarters amongst the fibrous feeding roots around the underground basal portions of the cane sticks.

These grubs of the first stage of growth can always be recognised at a glance by the width of head, which is  $\frac{1}{8}$  inch (never more or never less), remaining so throughout the period of the first instar, although, of course, the length of the entire grub varies from  $\frac{1}{4}$  to  $\frac{3}{8}$  inch, according to the number of days which may have elapsed since its first appearance.

#### METHODS OF CONTROLLING THE BEETLE STAGE.

##### Collecting Cane Beetles.

The practice of this common-sense remedial measure is more or less followed by growers in Australia, and has been found, on the whole, to yield beneficial results.

Such appears to have been the case also in other parts of the world wherever the grubs of lamellicorn beetles figure as being important economic problems. Growers in the Cairns district used at one time to collect their grubs and beetles, and this work could, I think, still be followed up with advantage by individual cane farmers.

The following additional methods of fighting the adult form of this cane pest should be mentioned here:—

1. Destruction of their feeding trees.
2. Capturing the beetles by means of light traps.
3. The use of soil deterrents against laying of the eggs.
4. Poisoning the leaves of their food plants.
5. More rigorous protection of our insectivorous birds.

Nos. 3, 4, and 5 are well worthy of closer study in the future, and considered from an economic standpoint present decided possibilities.

#### FACTS WHICH GROWERS SHOULD MEMORISE.

This being a beetle and egg month, an account of the grub condition of our Greyback will not be dealt with here, being reserved for the period of January to March, when the activities manifested during such phase of its life-history will doubtless claim their usual share of attention from cane farmers. With regard to the winged form of this cockchafer, however, growers should note the dates on which Greybacks from the primary brood or from any succeeding emergencies were first noticed on the wing in decided numbers. This point is very important, seeing that it is possible to determine from such dates later on the correct time for commencing fumigation work against the grubs with every likelihood of success.

The plate for this month shows Greyback beetles engaged in feeding on leaves—emerging from a pupal chamber (the track of its passage from same descending as indicated to a level below two egg chambers), and in the act of ovipositing. The eggs in one of these chambers are nearly ready to hatch, the female having—as indicated by tunnel—made its way again to the surface and flown off to feeding trees. Grubs of the first stage are shown just hatched from eggs, and others feeding on fibrous cane-roots near the surface.

